



SA115H-XXG

15W Switching Adapter

Input

Rated Voltage	100 - 240 VAC
Max. Voltage	90 - 264 VAC
Line Frequency	47 - 63 Hz
Current	400mA at 100-240VAC
Configuration	Europe - 2PIN

Output

Model Name	Voltage	Current	Watt	Eff. (typ.)
SA115H-09G	9V	1.7A	15.3W	80%
SA115H-12G	12V	1.3A	15.6W	80%

Line Regulation	Less than $\pm 2\%$
Load Regulation	Less than $\pm 5\%$
Protections	OCP, OVP & Short circuit
Ripple & Noise	$\leq 150\text{mVp-p}$

Environment

Operating Temp.	0°C - 40°C
Storage Temp.	-20°C - 80°C
Operating Humidity	10% - 90% (Non-condensing)
RoHS & WEEE	Standard

Reliability

MTBF	50,000 hrs (by MIL-217 Standard)
Safety	ITE: TUV/GS, CB, CE

Others

Package	80 pcs/box
Min. Order	1K pcs/lot
Warranty	1 year

Electrical

Topology	Switching Mode
Hi-Pot	3000 Vac/1sec @ 5mA (primary - secondary)
Leakage Current	$\leq 0.25\text{mA}$, at 264VAC/60Hz
Hold Up Time	$\geq 6\text{mSec}$
Standby Power	$\leq 0.3\text{ Watt}$ (As per CEC Consumption Guideline)
EMI	Complies with EMI directives
CEC Requirement	Efficiency Level : IV
Energy Star Requirement	EPS 2.0 (Efficiency Level V)

Mechanical

Case Size	75L x 50W x 30H mm
Case Material	Black, 94V-1 or equivalent
Weight	130 \pm 10 g
DC Cord	4.92ft

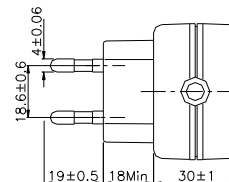
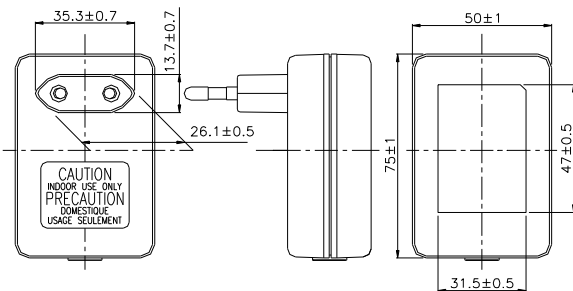

For reference only. For details please contact your local sales representative.